

Control iD

iDFace - Quick Guide

Thank you for purchasing the iDFace! For detailed information about your new product, please check the following link:

www.controlid.com.br/userguide/idface-max.pdf

Necessary Materials

In order to install your iDFace, you will need the following items: drill, wall plugs and screws, screwdriver, 12V power supply rated for at least 2A and an electronic lock.

Installation

For the correct operation of your iDFace, the following precautions must be taken:

- Install in a place that is not exposed to direct sunlight. This lighting factor must be considered in order to ensure the quality of the captured images.
- Avoid metallic objects near the rear of the device in order not to impair the proximity reader's range. In case this is not possible, use insulating spacers.
- Before securing the device in place, ensure all connecting cables are correctly routed towards the device.
- Fix the bottom part of the wall support for iDFace at 1.35m from the ground for the passage of people or at 1.20m for the recognition of a person inside a car.

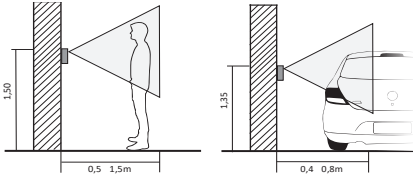

Installing the equipment is simple and must follow the diagram below:

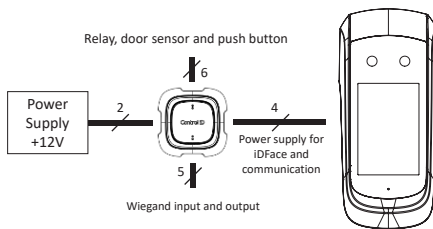

1. For greater security during the installation, place the External Access Module (EAM) in a secure region (internal area of the facility).
2. Use the reference pattern in the back of this guide to drill the 3 holes required to install the iDFace and fit the wall plugs in.
3. Connect the EAM to a +12V power source and to the lock using the cables supplied.
4. Prepare a 4 - way cable long enough to connect the EAM to the iDFace. For distances greater than 5m, use a twisted pair cable for the data signals. If you choose a Cat 5 cable to connect the EAM to the iDFace, use 3 pairs for power and 1 pair for the data signals. In this case, the distance cannot surpass 25m. Remember to use the same pair for signals A and B.
Recommended installation configuration for Cat5 cable:

+12V	Green+Orange+Brown
GND	Green/Wh + Orange/Wh + Brown/Wh
A	Blue
B	Blue/Wh

5. Connect the wire harness provided with the iDFace to the 4 wires in the previous item.
6. Remove the wall support from the iDFace.

7. Screw the wall mount bracket into the wall plugs.
8. Remove the sealing lid from the bottom and connect the 4-way wire to the iDFace.

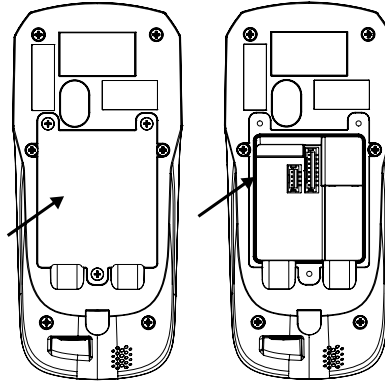

9. Insert and fix the lid and the sealing rubber.
⚠ The lid and sealing rubber are essential for protection. Please make sure to position and fix them on the back of the product properly.
10. Secure the iDFace on the wall support and secure it in place with the screws provided together with the connection cables.

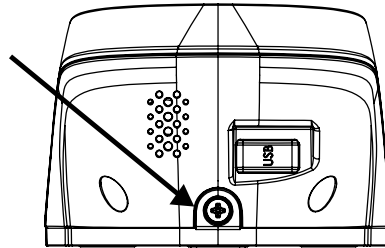

Description of Connection Pins

On your iDFace, there is a connector on the back of the device, right next to the network connector (Ethernet). In the External Access Module (EAM) there is a matching connector and 3 other connecting pins that will be used to connect locks, switches and scanners as explained ahead.

iDFace: 4-pin Connector

GND	Black	Power supply ground
B	Blue/Wh	Communication B
A	Blue	Communication A
+12V	Red	+12 Power Supply

EAM: 2-pin Connector (Power Supply)

+12V	Red	Power supply +12V
GND	Black	Power supply ground

⚠ The connection to a +12V power supply rated for at least 2A is fundamental for the correct operation of the device.

EAM: 4-pin Connector

GND	Black	Power supply ground
B	Blue/Wh	Communication B
A	Blue	Communication A
+12V	Red	Output +12V

EAM: 5-pin Connector (Wiegand In/Out)

WOUT0	Yellow/Wh	Wiegand output - DATA0
WOUT1	Yellow	Wiegand output - DATA1
GND	Black	Ground (Common)
WIN0	Green/Wh	Wiegand input - DATA0
WIN1	Green	Wiegand input - Data1

⚠ External card readers should be connected to WIN0 and WIN1. In case there is a control board, one can connect the

Wiegand WOUT0 and WOUT1 outputs to the control board so that the user's ID identified in the iDFace is transferred to it.

EAM - 6-pin connector (Door Control/Relay)

DS	Purple	Door Sensor Input
GND	Black	Ground (common)
BT	Yellow	Push Button Input
NC	Green	Normally Closed Contact
COM	Orange	Common Contact
NO	Blue	Normally Open Contact

⚠ The push button and door sensor inputs can be configured as NO or NC and must be connected to dry contacts (switches, relays, etc...) between GND and the respective pin.

⚠ Internal relay of EAM has a maximum voltage of +30VDC.

EAM - Communication Modes

- Default: EAM will communicate with any equipment.
 - Advanced: EAM will only communicate with the equipment to which it was configured in this mode.
- ⚠ To return EAM to default mode, turn it off, connect WOUT1 pin with BT and then turn it on. The LED will flash rapidly 20x indicating that the change has been made.

iDFace Settings

The configuration of all the parameters of your new iDFace can be set through the LCD display (Graphical User Interface – GUI) and/or through a standard internet browser (as long as the iDFace is connected to an Ethernet network and have this interface enabled).

In order to configure, for example, the IP address, subnet mask and gateway, through the touch screen, follow these steps: Menu → Settings → Network. Update the information as you wish and connect the device to the network.

Web Interface Settings

First, connect the device directly to a PC using an Ethernet cable (cross or direct). Next, set a fixed IP on your computer for network 192.168.0.xxx (where xxx is different from 129 so that there is no IP conflict) and mask 255.255.255.0.

To access the device settings screen, open a web browser and enter the following URL:

<http://192.168.0.129>

The login screen will be shown. The default access credentials are:

- Username: admin
- Password: admin

⚠ Through the web interface you can change the device's IP. If you change this parameter, remember to write down the new value so that you can connect to the product again.

User Enrollment and Identification

The quality of a facial identification system is directly related to the quality of the image captured by the iDFace during the enrollment stage. Thus, during this process, please make sure that the face is aligned to the camera and is 50 cm away. Avoid atypical facial expressions and objects that can hide important regions of the face (mask, sunglasses and others).

For the identification process, position yourself in front and inside the field of view of the iDFace's camera and wait for the indication of access allowed or denied in the product's display.

⚠ Avoid using objects that can block the capture of the eyes.

⚠ It is recommended that the distance between the device and the user (1.45-1.80m tall) be between 0.5 and 1.5 m. Ensure that you are positioned within the camera's field of view.

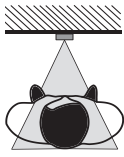

Electronic Lock Types

iDFace, through the relay in the External Access Module, is compatible with almost all of the locks available in the market.

Magnetic Lock

The magnetic or electromagnetic lock consists of a coil (fixed part) and a metal part (armature plate) which is attached to the door (mobile part). While there is a current passing through the magnetic lock, the fixed part will attract the mobile part. When the distance between these two parts is small, i.e. when the door is closed and the dock is on top of the fixed part, the attraction force between the parts can reach over 1000kgf.

Thus, the magnetic lock is normally connected to the NC contact of the activation relay, as we normally want for the current to go through the electromagnet and, if we want the door to open, the relay must open and interrupt the current flow.

In this guide, the magnetic lock will be represented by:



Electric Bolt

The electric bolt lock, also known as solenoid lock, consists of a fixed part with a mobile pin connected to a solenoid. The lock normally comes with a metal plate that will be attached to the door (mobile part).

The pin on the fixed part enters the metal plate preventing the door from opening.

In this guide, the solenoid pin lock will be represented by:

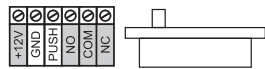

⚠️ Terminals indicated in gray may not be present on all locks. If there is a power input (+12V or +24V), it is essential to connect it to a source before operating the lock.

Electromechanical Lock

The electromechanical lock or strike lock consists of a latch connected to a solenoid through a simple mechanism. After opening the door, the mechanism returns to its initial state allowing the door to be closed again.

Thus, the electromechanical lock typically has two terminals connected directly to the solenoid. When current passes through the lock, the door will be unlocked.

In this guide, the electromechanical lock will be represented by:



⚠️ Confirm the operating voltage of the lock before connecting it to the iDFace! Many electromechanical locks operate at 110V/220V and therefore require a different connection.

Wiring Diagrams

Connection of iDFace Max and EAM – Mandatory

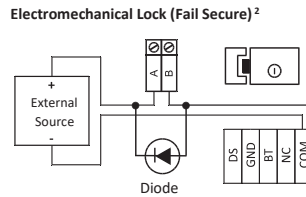
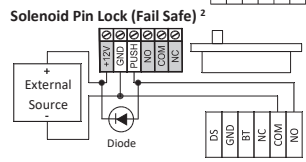
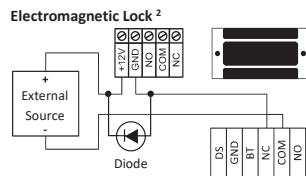
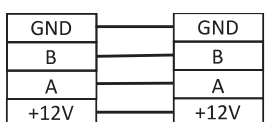

⚠️ We recommend the use of an exclusive power supply to source power to the Electromechanical Lock.

Push Button and Door Sensor

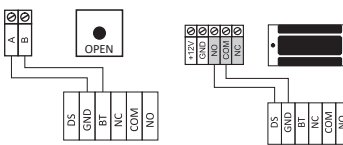

Safety Instructions

Please follow the recommended conditions below to ensure the correct use of the equipment to prevent injuries and damage.

Power Supply	+12VDC, 2A CE LPS (Limited Power Supply) Certified)
Storage Temperature	0°C to 40 °C
Operating Temperature	-20 °C to 45 °C
Operating Frequency	125 kHz
Maximum Field Strength	IDFACEFPA: 80dBµV/m @ 3m at 125kHz, equivalent to -17dBm (ERP)
	IDFACEFPM: 55dBuV/m @ 3m at 13.56MHz equivalent to -42dBm (ERP)

When purchasing iDFace, the following items are included in the package: 1x iDFace, 1x EAM, 1x 2-pin cable for power supply, 2x 4-pin for interconnecting iDFace and EAM, 1x 5-pin cable for optional Wiegand communication, 1x 6-pin cable for use internal relay and sensors signals, 1x generic diode for protection when using a magnetic lock.

ISED compliance statement

This device complies with Industry Canada licence-exempt RSS standard(s). Operation is subject to the following two conditions: This device may not cause interference; and this device must accept any interference, including interference that may cause undesired operation of the device.

Le présent appareil est conforme aux CNR d'Industrie Canada applicables aux appareils radio exempts de licence. L'exploitation est autorisée aux deux conditions suivantes: l'appareil ne doit pas produire de brouillage et l'utilisateur de l'appareil doit accepter tout brouillage radioélectrique subi, même si le brouillage est susceptible d'en compromettre le fonctionnement.

FCC Warning Statement

This device complies with Part 15 FCC Rules. Operation is subject to the following two conditions: (1) This device may not cause harmful interference. (2) This device must accept any interference received including interference that may cause undesired operation.

Note: This equipment has been tested and found to comply with the limits for a Class B digital device, pursuant to part 15 of the FCC Rules. These limits are designed to provide reasonable protection against harmful interference in a residential

installation.

This equipment generates, uses, and can radiate radio frequency energy and, if not installed and used in accordance with the instructions, may cause harmful interference to radio communications. However, there is no guarantee that interference will not occur in a particular installation.

If this equipment does cause harmful interference to radio or television reception, which can be determined by turning the equipment off and on, the user is encouraged to try to correct the interference by one or more of the following measures:

- Reorient or relocate the receiving antenna.
- Increase the separation between the equipment and receiver.
- Connect the equipment to an outlet on a circuit different from that to which the receiver is connected.
- Consult the dealer or an experienced radio/TV technician for help.

Changes or modifications to this product not authorized by Control ID could void the electromagnetic compatibility (EMC) and wireless compliance and negate your authority to operate the product.

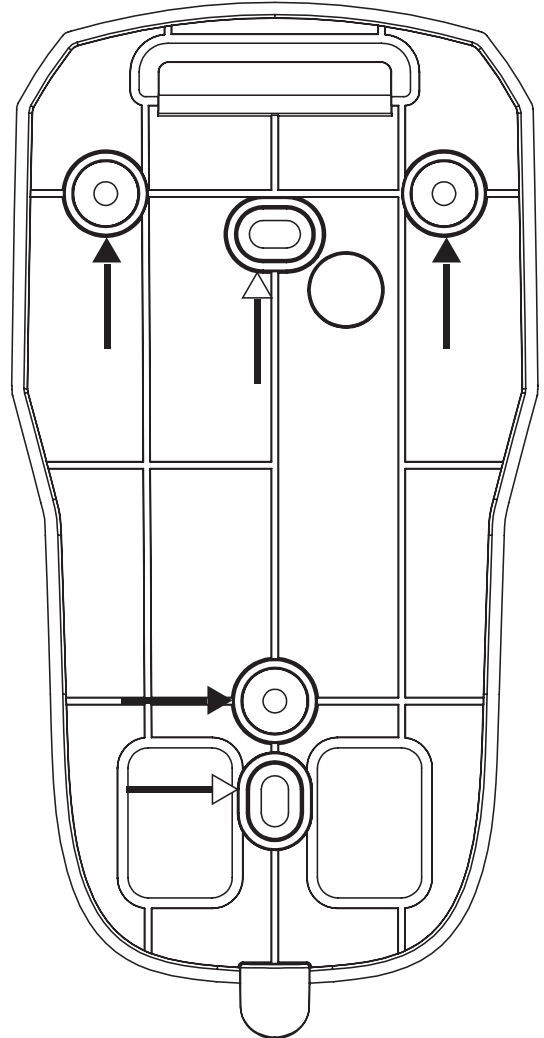

➔ Holes for wall fixing

➔ Holes for box fixing

For Technical and Customer Support:

techsupport.controlid.us@assaabloy.com

customerservice.controlid.us@assaabloy.com

1-888-977-9822

M-F 8:00am - 6:30pm EST

Manufactured by: Controlid Industria e Comercio de Hardware e Servicos De Tecnologia Ltda Rua Hungria, 888, 8th Floor, Sao Paulo SP, 01455000 – Brazil. Imported by: ASSA ABLOY AB - Klarabergsviadukten 90, Stockholm, Sweden (Europe) and ASSA ABLOY UK - ASSA ABLOY Limited, Portobello, School Street, Willenhall, WV13 3PW (UK).